



# GENERATOR TYPE ECP 3-1L/2

Document : DS156A/1

issue 002 date 05/05/2014

Electrical Characteristics										
Frequency	Hz	50				60				
Voltage (series star)	V	380	400	415	440	415	440	460	480	
Rated power class H	kVA	16	16	16	13	17	19,2	19,2	19,2	
	kW	12,8	12,8	12,8	10,4	13,6	15,4	15,4	15,4	
Rated power class F	kVA	14,5	14,5	14,5	11,5	14	17	17	17	
	kW	11,6	11,6	11,6	9,2	11,2	13,6	13,6	13,6	
Regulation with	DSR	±1 % with any power factor and speed variations between -5% +30%								
Insulation class		H								
Execution		Brushless								
Stator winding		12 ends								
Rotor		with damping cage								
Efficiencies class H	4/4	%	84,4	84,5	84,2	84	85,4	85,9	86	86,1
(see graph. for details)	3/4	%	84,7	85	84,9	84,6	86	86,2	86,4	86,6
	2/4	%	81,4	81,5	81,5	81,2	83,2	83,3	83,4	83,5
	1/4	%	77,1	77	76,8	76,3	77,8	77,6	77,7	78
Reactances (f. l.cl. F)	Xd	%	223,8	202	187,7	135,6	239,3	240,4	219,9	202
	Xd'	%	30,9	27,9	25,9	18,7	33	33,2	30,4	27,9
	Xd''	%	16,7	15,1	14	10,1	17,9	18	16,4	15,1
	Xq	%	110,1	99,4	92,3	66,7	117,7	118,3	108,2	99,4
	Xq'	%	110,1	99,4	92,3	66,7	117,7	118,3	108,2	99,4
	Xq''	%	42,3	38,2	35,5	25,7	45,2	45,5	41,6	38,2
	X <sub>2</sub>	%	19,4	17,5	16,3	11,8	20,7	20,8	19,1	17,5
	X <sub>0</sub>	%	6,6	6	5,6	4	7,1	7,1	6,5	6
Short Circuit Ratio	Kcc		0,43	0,55	0,76	1,38	0,30	0,38	0,43	0,55
Time Constants	Td'	sec.	0,062							
	Td''	sec.	0,014							
	Tdo'	sec.	0,67							
	T <sub>α</sub>	sec.	0,012							
Short Circuit Current Capacity		%	>300				>320			
Excitation at no load	Amp.		0,25	0,3	0,37	0,4	0,18	0,2	0,24	0,28
Excitation at full load	Amp.		1,1	1,2	1,25	1,3	0,95	1	1,05	1,1
Overload (long-term)		%	1 hour in a 6 hours period 110% rated load							
Overload per 20 sec.		%	300							
Stator Winding Resistance (20°C)	Ω		0,256							
Rotor Winding Resistance (20°C)	Ω		9,487							
Exciter Resistance (20 °C)	Ω		Rotor : 1,453				Stator : 15,71			
Heat dissipation at f.l.cl.H	W		2366	2348	2402	1981	2325	2521	2500	2480
Telephone Interference			THF < 2%				TIF < 45			
Radio interference			EN61000-6-3, EN61000-6-2. For others standards apply to factory							
Waveform Distors.(THD) at f. load	LL/LN %		4,6/ 4,4							
Waveform Distors.(THD) at no load	LL/LN %		3,8/ 3,7							
<b>Mechanical characteristics</b>										
Protection			IP 23 (other protection on request)							
DE bearing			6308-2RS							
NDE bearing			6305-2RS							
Weight of wound stator assembly	kg		24,6							
Weight of wound rotor assembly	kg		15,5							
Weight of complete generator	kg		80							
Maximun overspeed	rpm		4500							
Unbalanced magnetic pull at f.l.cl.F	kN/mm		2,9							
Cooling air requirement	m³/min		6				7,2			
Inertia Constant (H)	sec.		0,160				0,195			
Noise level at 1m/7m	dB(A)		85 / 70				89 / 73			

All technical data are to be considered as a reference and they can be modified without any notice.

This document is a propriety of Mecc Alte S.p.a..All rights reserved.



GENERATOR TYPE ECP 3-1L/2

Document : DS156A/2

issue 002 date : 05/05/2014

**50 Hz**

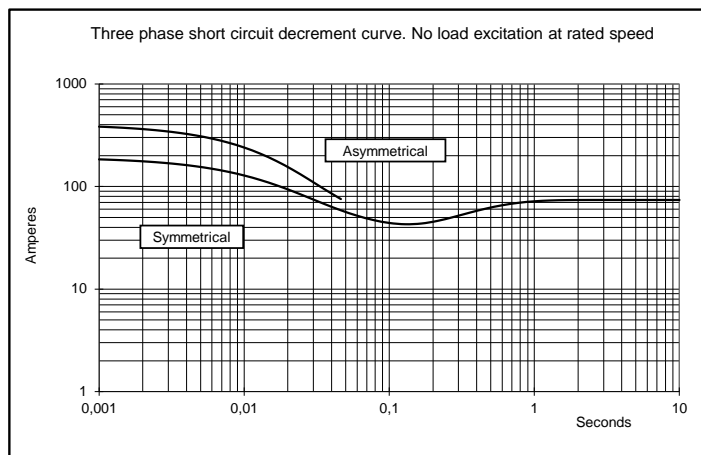
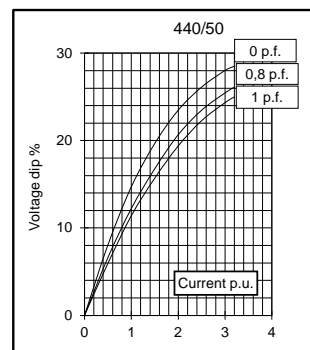
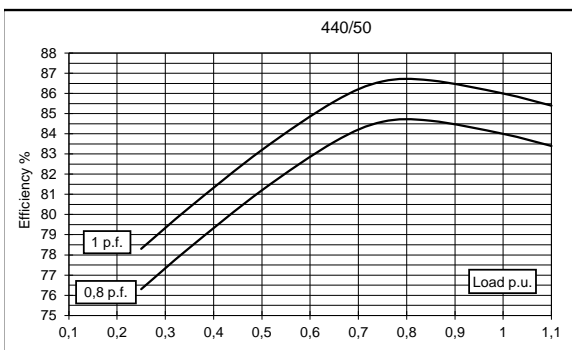
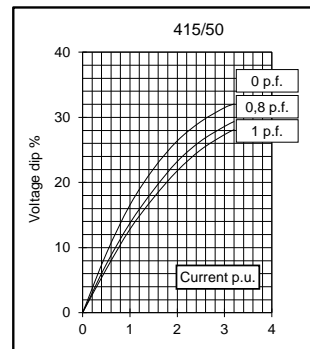
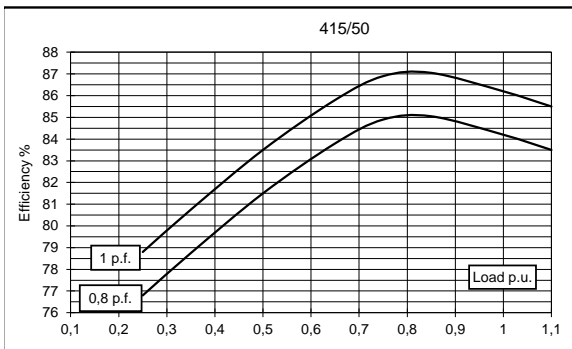
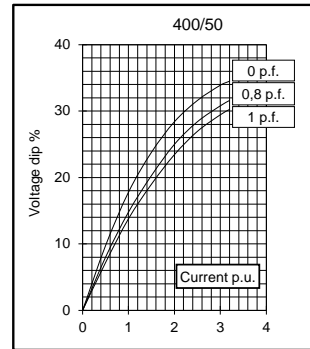
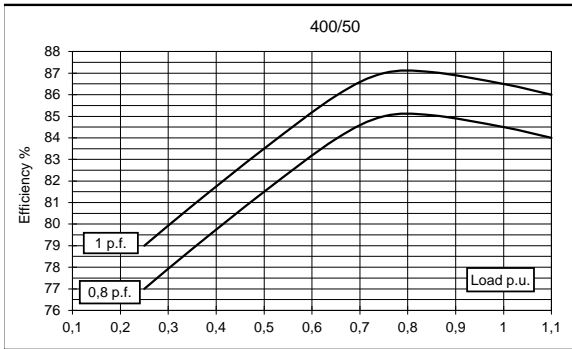
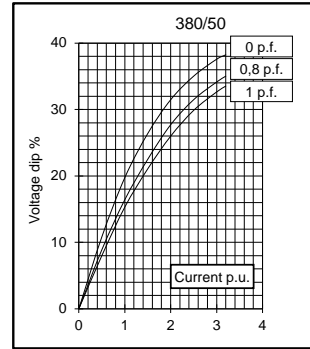
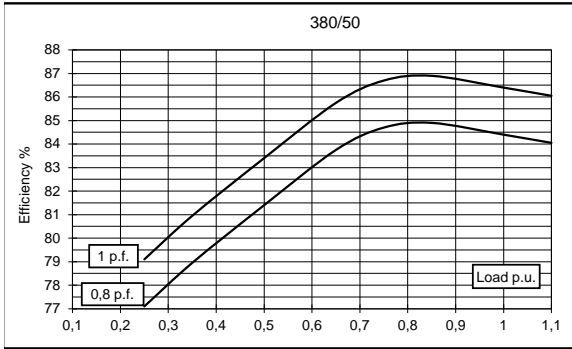

**60 Hz**

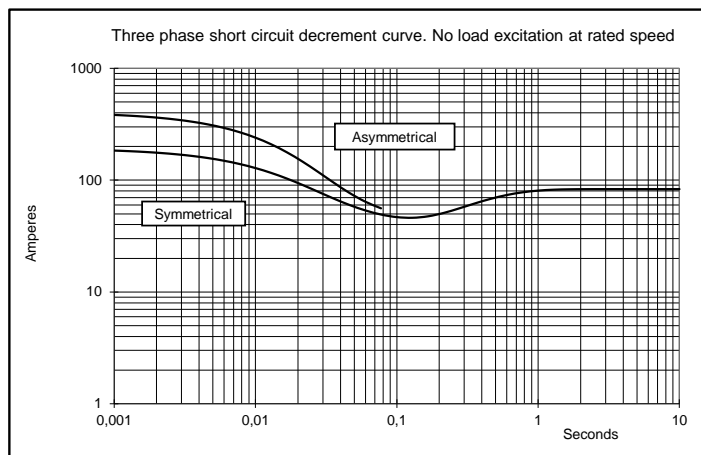
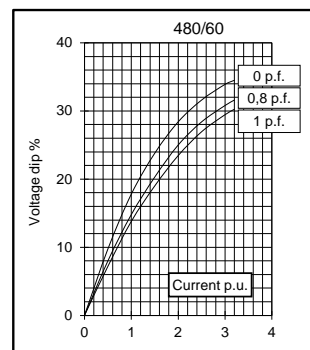
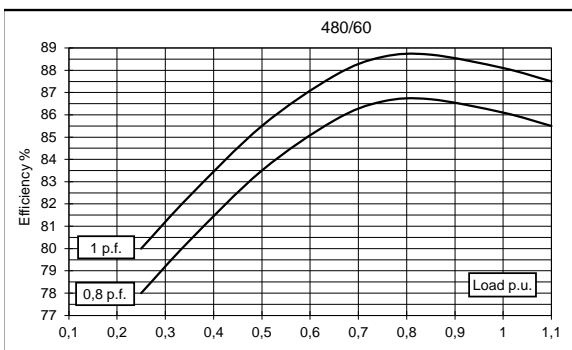
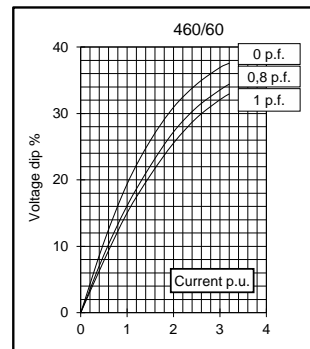
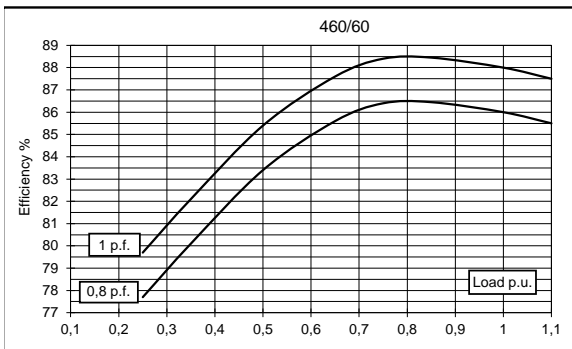
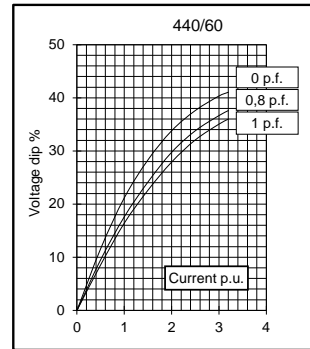
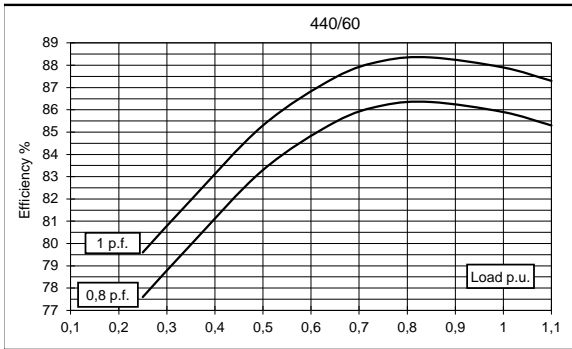
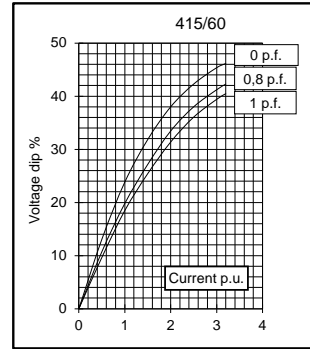
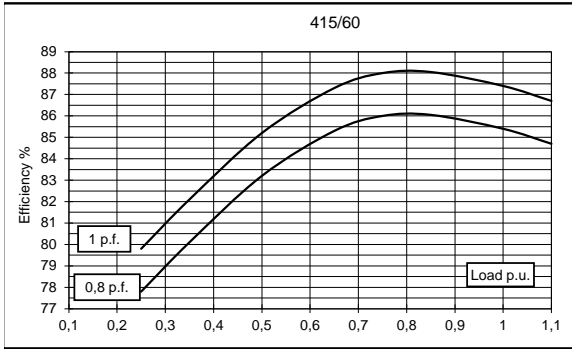



### SINGLE BEARING MOMENTS OF INERTIA

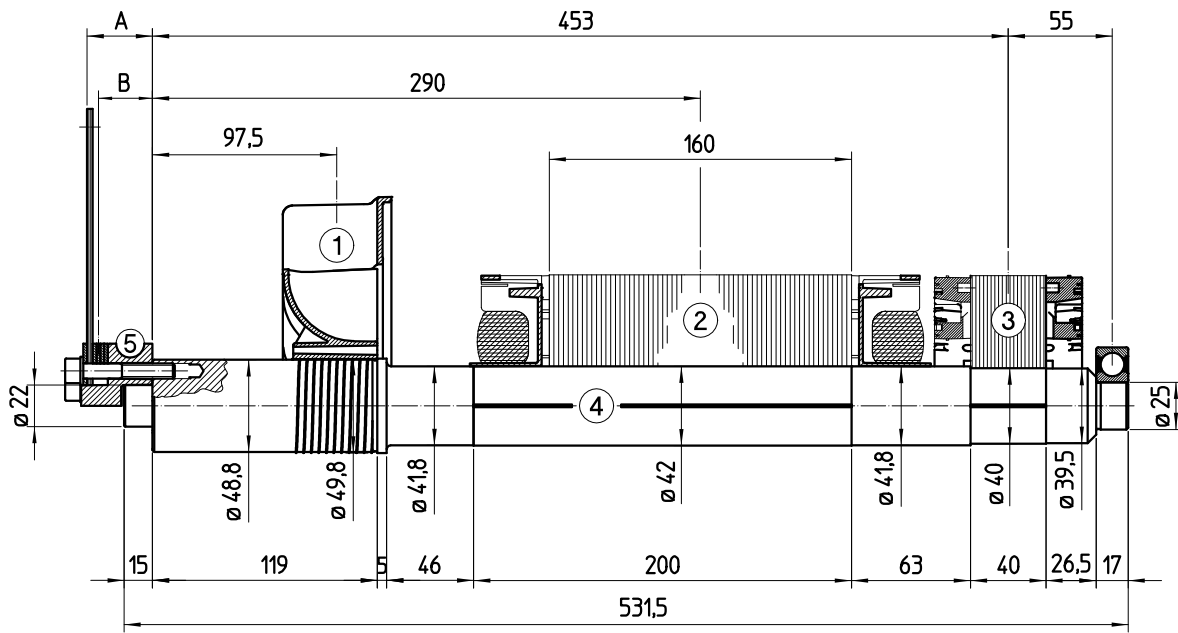

POS.	COMPONENT	WEIGHT (kg)	J (kgm <sup>2</sup> )
1	FAN	0,4	0,00206
2	MAIN ROTOR	15,5	0,03755
3	EX. ROTOR	4,2	0,01086
4	SHAFT	5,8	0,00140
TOTAL		25,9	0,05187

SAE N°	SHAFTS COUPLING FLEX PLATE		WEIGHT kg	J kgm <sup>2</sup>
	A	B		
6 1/2	3	1,5	1,00	0,00495
7 1/2	3	1,5	1,20	0,00769
8	34,6	29,5	1,75	0,01114
10	26,6	23,5	2,14	0,02220
11 1/2	13	11	2,60	0,03524

### SINGLE BEARING DIMENSIONS

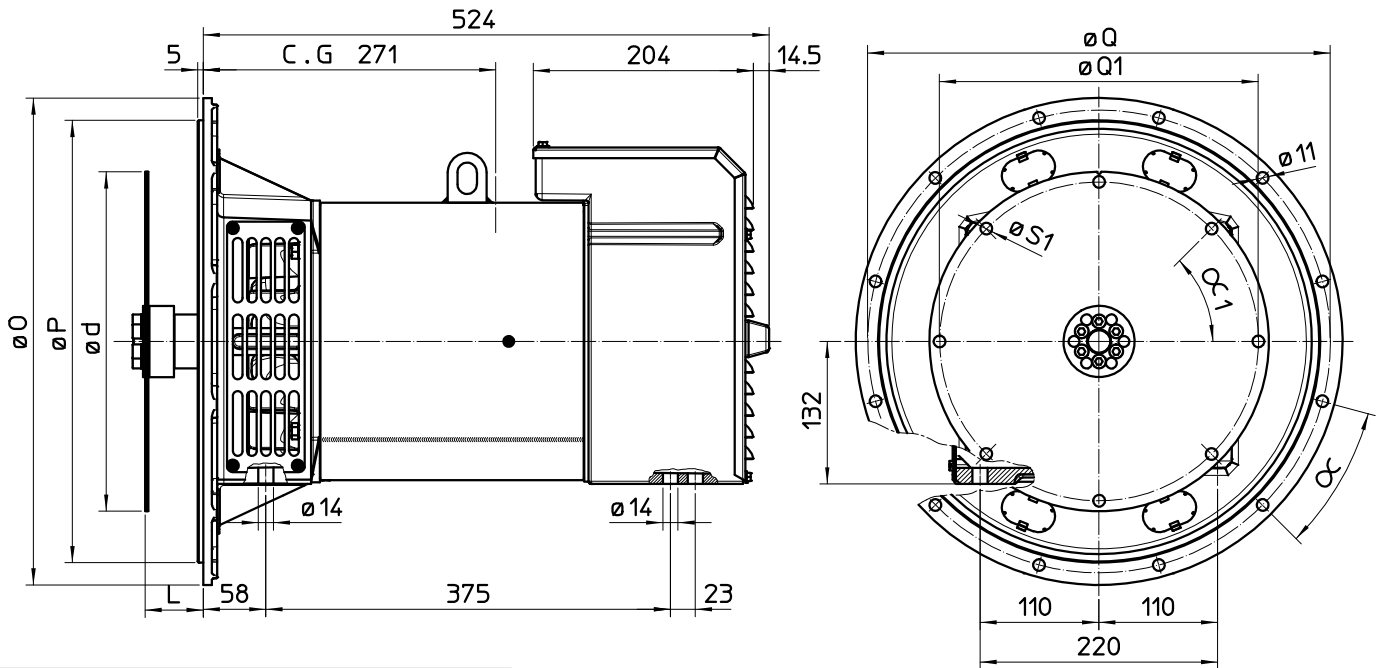

GIUNTO A DISCO / COUPLING DISC PLATEX						
SAE	L	d	Q1	Fori N° Holes N°	S1	α <sub>1</sub>
6 ‡	30,2	215,9	200	6	9	60°
7 ‡	30,2	241,3	222,25	8	9	45°
8	62	263,52	244,47	6	11	60°
10	53,8	314,52	295,27	8	11	45°
11 ‡	39,6	352,42	333,37	8	11	45°

FLANGIE / FLANGE					
SAE	O	P	Q	Fori N° Holes N°	α
6	308	266,7	285,75	8	22°30'
5	356	314,3	333,4	8	22°30'
4	403	362	381	12	15°
3	451	409,6	428,6	12	15°

C.G.= GRAVITY CENTER