



GENERATOR TYPE ECP 28-M/2

Document : **DS209A/1**
 issue 000 date 02/08/2012

Electrical Characteristics										
Frequency	Hz	50				60				
Voltage (star)	V	380	400	415	440	415	440	460	480	
Rated power class H	kVA	22	22	22	19	22	25	26,5	26,5	
	kW	17,6	17,6	17,6	15,2	17,6	20	21,2	21,2	
Rated power class F	kVA	20	20	20	17	20	23	24	24	
	kW	16	16	16	13,6	16	18,4	19,2	19,2	
Regulation with	DSR	±1 % with any power factor and speed variations between -5% +30%								
Insulation class		H								
Execution		Brushless								
Stator winding		12 ends								
Rotor		with damping cage								
Efficiencies class H	4/4	%	85,1	85,2	84,9	84,7	85,5	86	86,1	86,2
(see graph. for details)	3/4	%	85,5	85,8	85,7	85,4	86,5	86,7	86,9	87,1
	2/4	%	83,4	83,5	83,5	83,2	84,7	84,8	84,9	85
	1/4	%	80,1	80	79,8	79,3	80,8	80,6	80,7	81
Reactances (f. l.cl. F)	Xd	%	227,9	205,7	191,1	146,8	228,5	230,9	224,0	206
	Xd'	%	8,64	7,8	7,25	5,57	8,66	8,76	8,49	7,8
	Xd''	%	5,21	4,7	4,37	3,35	5,22	5,28	5,12	4,7
	Xq	%	130,7	118	109,6	84,2	131,1	132,5	128,5	118
	Xq'	%	130,7	118	109,6	84,2	131,1	132,5	128,5	118
	Xq''	%	30,1	27,2	25,3	19,4	30,2	30,5	29,6	27,2
	X ₂	%	15,29	13,8	12,82	9,85	15,33	15,49	15,03	13,8
	X ₀	%	6,76	6,1	5,67	4,35	6,77	6,85	6,64	6,1
Short Circuit Ratio	Kcc		0,98	1,1	1,31	1,50	0,85	0,93	0,98	1,1
Time Constants	Td'	sec.	0,039							
	Td''	sec.	0,011							
	Tdo'	sec.	0,68							
	Tα	sec.	0,027							
Short Circuit Current Capacity		%	>300				>320			
Excitation at no load	Amp.		0,48	0,53	0,6	0,8	0,35	0,4	0,45	0,5
Excitation at full load	Amp.		1,3	1,4	1,6	1,6	1,1	1,1	1,2	1,3
Overload (long-term)		%	1 hour in a 6 hours period 110% rated load							
Overload per 20 sec.		%	300							
Stator Winding Resistance (20 °C)	Ω		0,148							
Rotor Winding Resistance (20 °C)	Ω		4,877							
Exciter Resistance (20 °C)	Ω		Rotor : 0,417				Stator : 10,60			
Heat dissipation at f.l.cl.H	W		3082	3057	3130	2746	2985	3256	3423	3394
Telephone Interference			THF < 2%				TIF < 45			
Radio interference			EN61000-6-3, EN61000-6-1. For others standards apply to factory							
Waveform Distors.(THD) at f. load	LL/LN %		2,4 / 3,7							
Waveform Distors.(THD) at no load	LL/LN %		2,9 / 4,5							
Mechanical characteristics										
Protection			IP 23 (other protection on request)							
DE bearing			6309-2RS							
NDE bearing			6207-2RS							
Weight of wound stator assembly	kg		39,6							
Weight of wound rotor assembly	kg		18,8							
Weight of complete generator	kg		126							
Maximun overspeed	rpm		4500							
Unbalanced magnetic pull at f.l.cl.F	kN/mm		3,2							
Cooling air requirement	m³/min		9,7				11			
Inertia Constant (H)	sec.		0,224				0,268			
Noise level at 1m/7m	dB(A)		86 / 74				90,5 / 78			

50 Hz

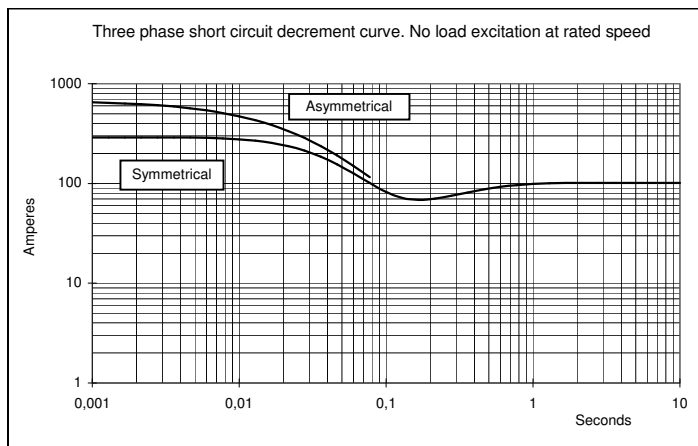
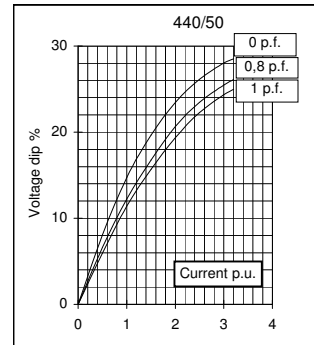
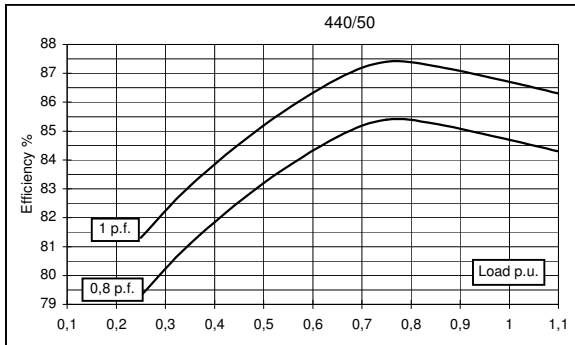
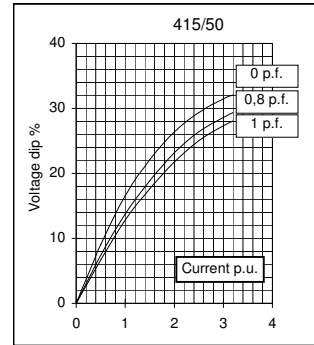
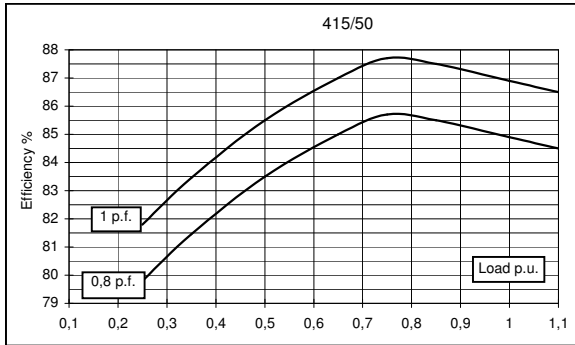
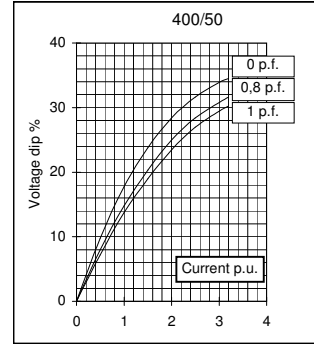
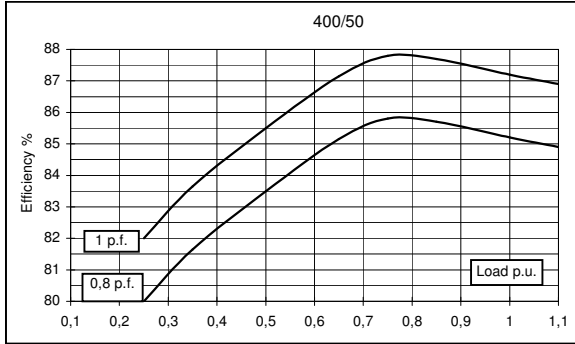
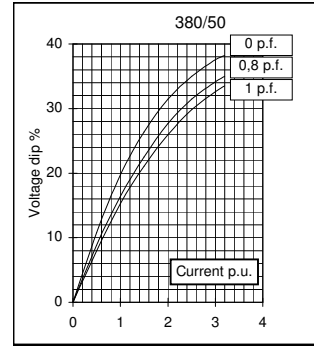
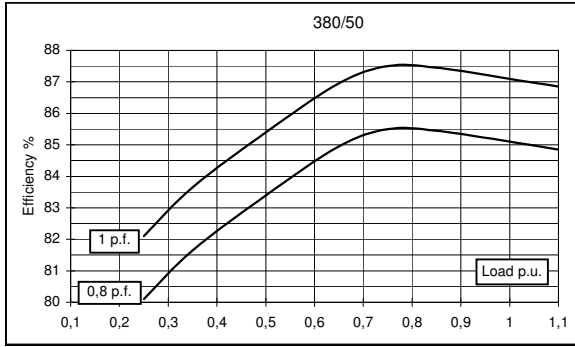

60 Hz

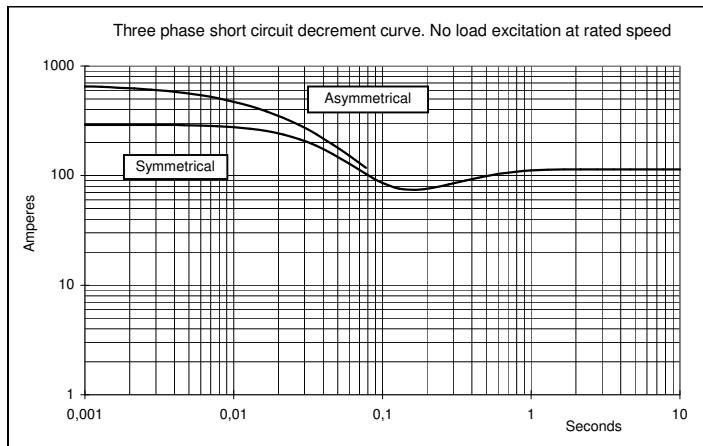
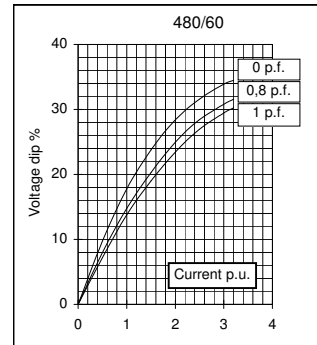
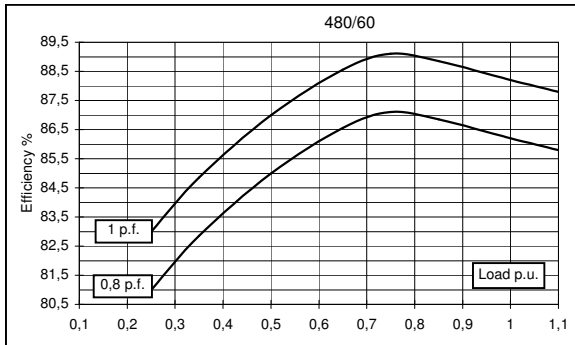
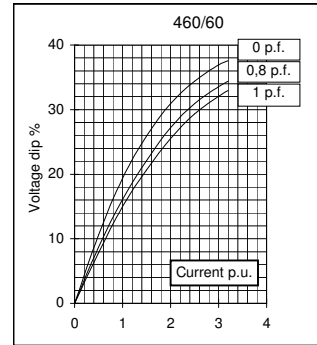
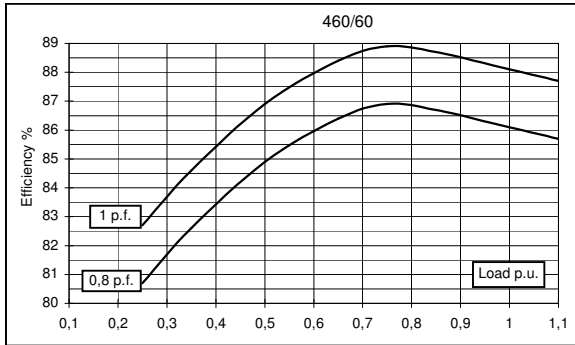
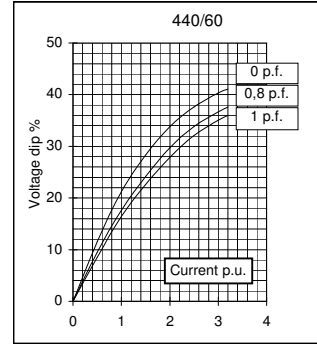
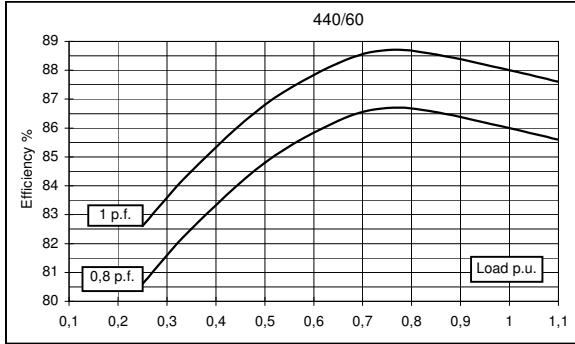
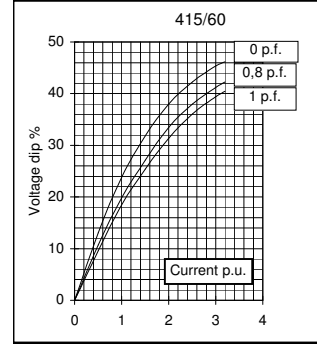
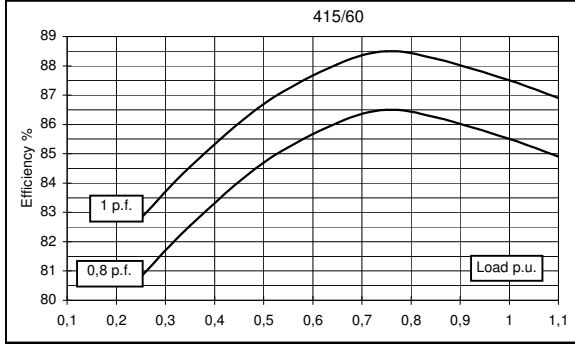

TWO BEARING MOMENTS OF INERTIA

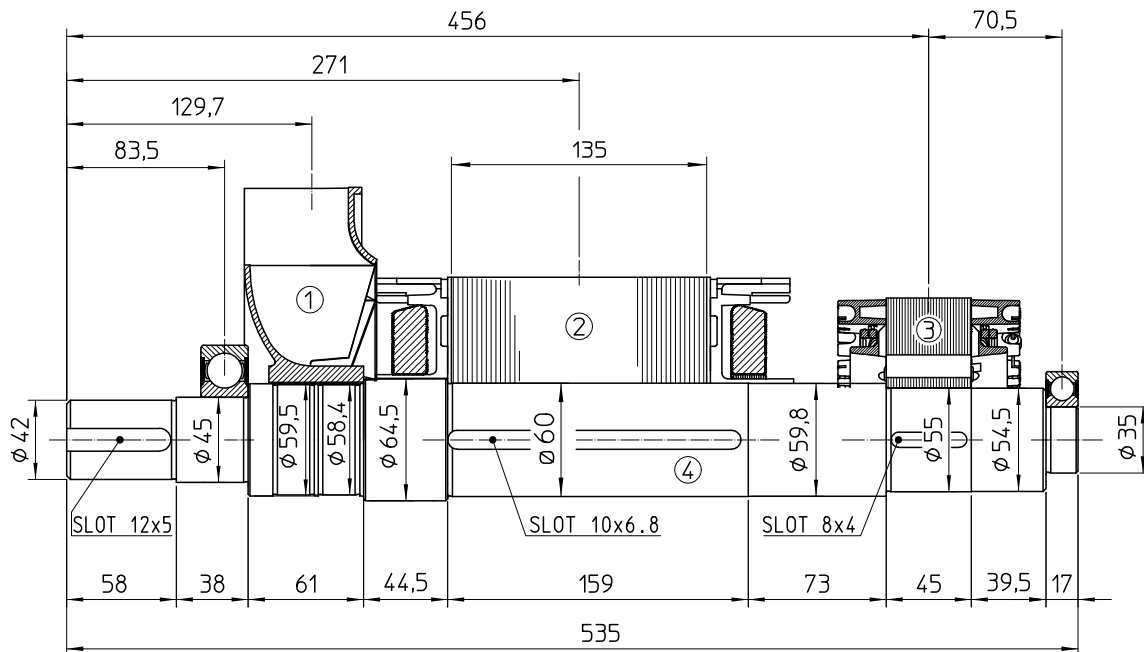

POS.	COMPONENT	WEIGHT (kg)	J (kgm ²)
1	FAN	1.2	0.0087
2	MAIN ROTOR	18.8	0.069
3	EX. ROTOR	5.5	0.0172
4	SHAFT	10.1	0.0042
TOTAL		38.3	0.1182

TWO BEARING DIMENSIONS

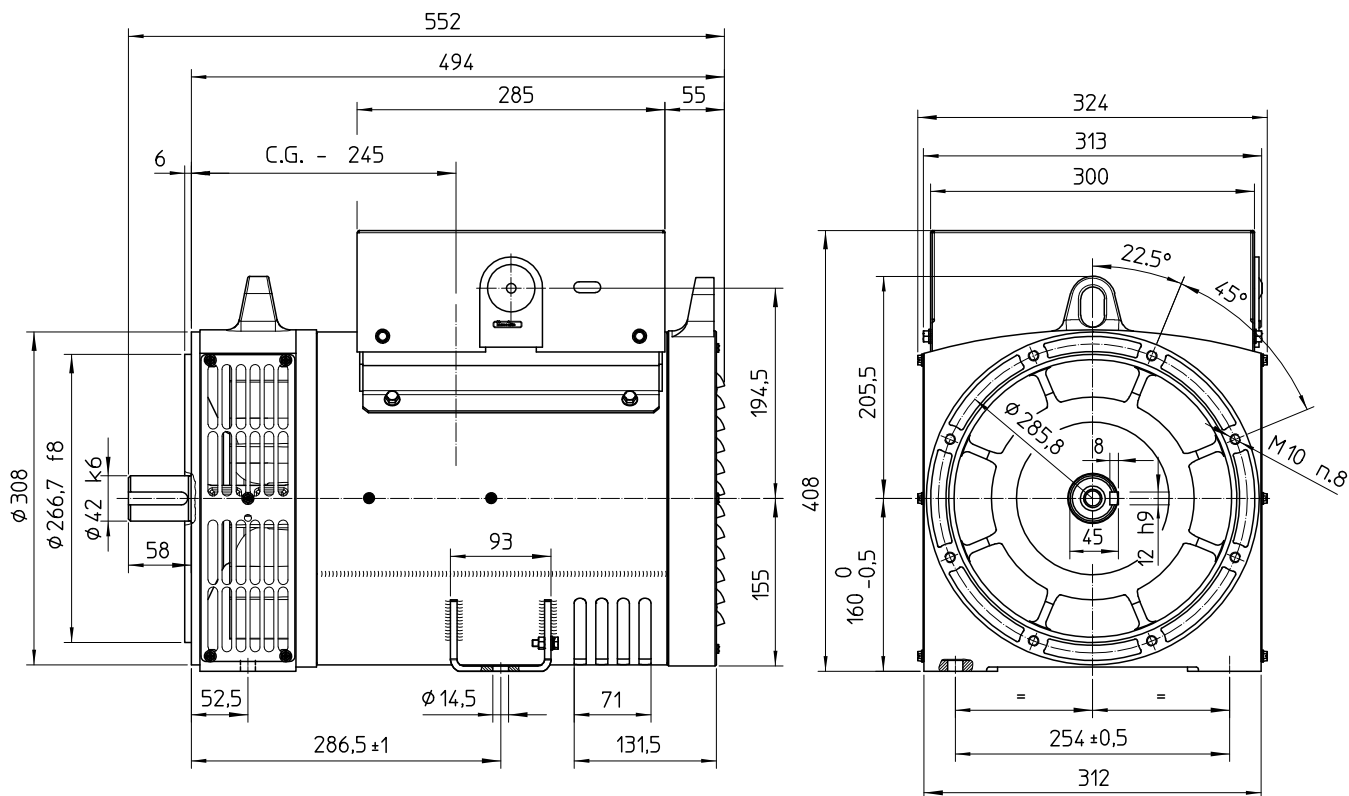

C.G.= GRAVITY CENTER

SINGLE BEARING MOMENTS OF INERTIA

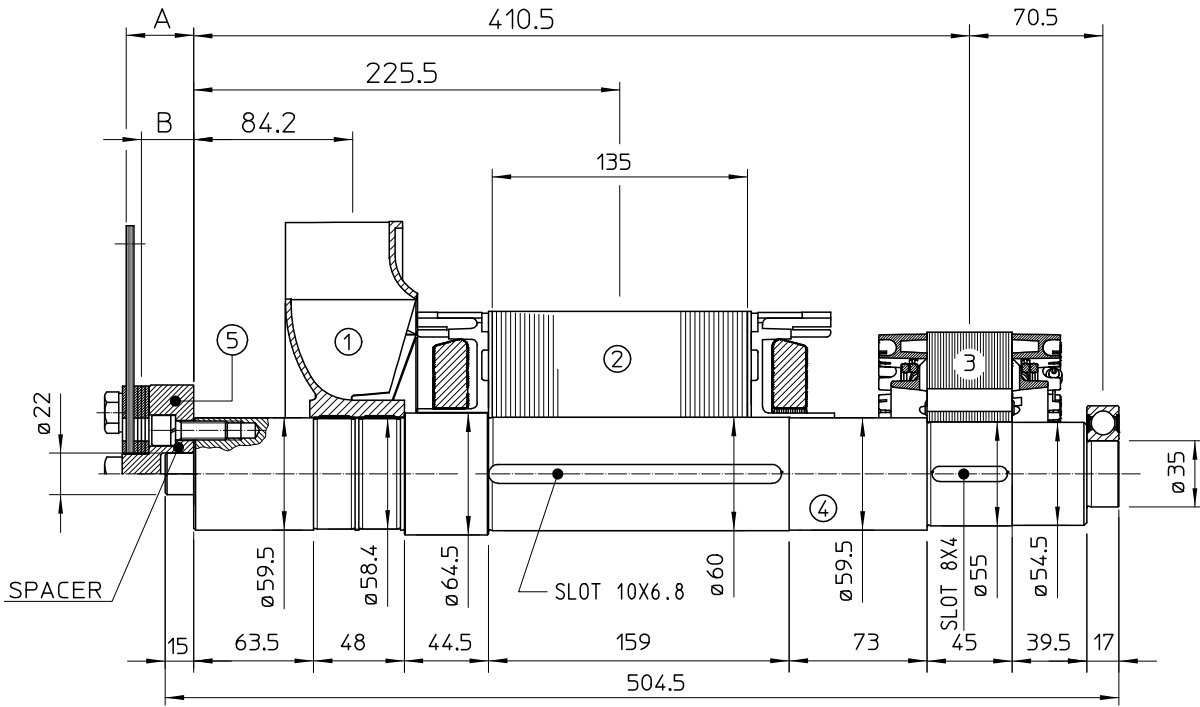

POS.	COMPONENT	WEIGHT (kg)	J (kgm ²)
1	FAN	1.2	0.0087
2	MAIN ROTOR	18.8	0.069
3	EX. ROTOR	5.5	0.0172
4	SHAFT	10.1	0.0044
TOTAL		35.6	0.0993

SAE N°	5		SHAFTS COUPLING FLEX PLATE	
	A	B	WEIGHT kg	J kgm ²
6 1/2	4	2	1.08	0.0065
7 1/2	4	2	1.35	0.0101
8	35.6	28.3	2.84	0.0158
10	27.6	22.9	3.25	0.0303
11 1/2	14	11.2	3.6	0.471

SINGLE BEARING DIMENSIONS

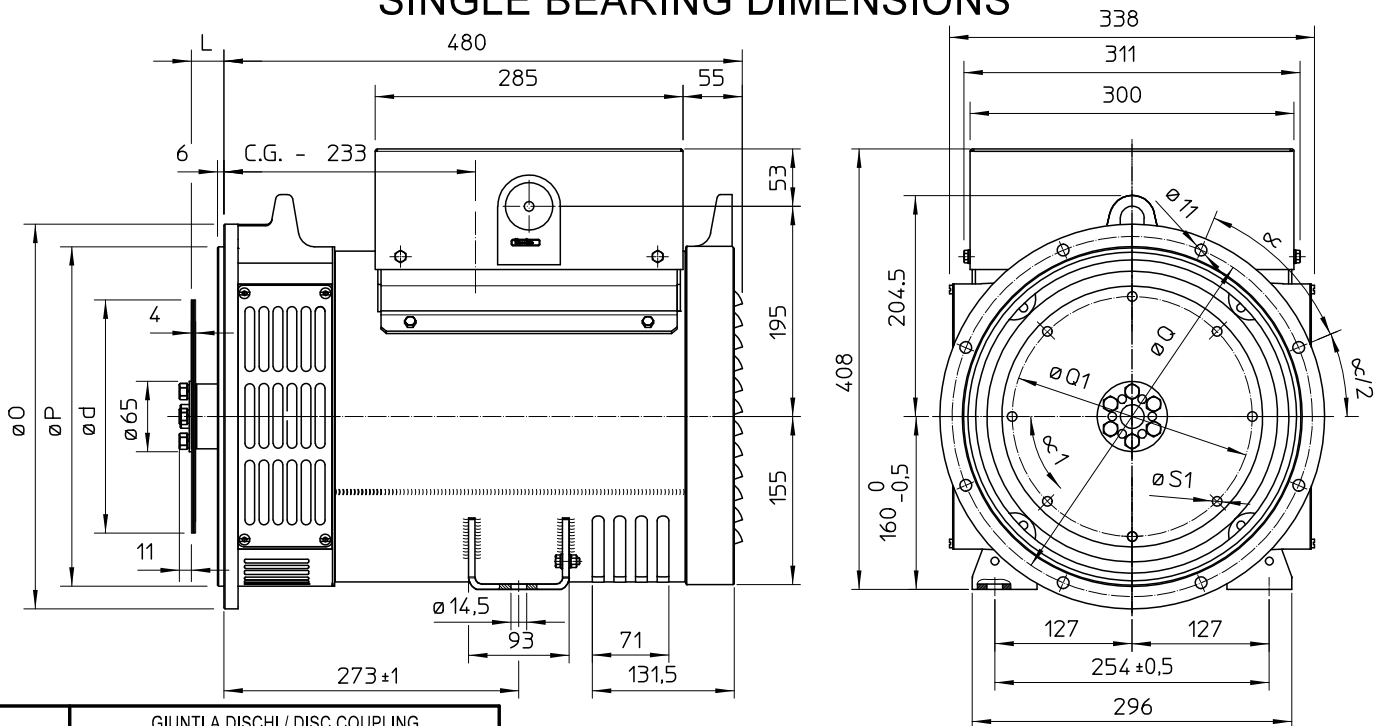

SAE N.	GIUNTI A DISCHI / DISC COUPLING DISCQUE DE MONOPALIER / SCHEIBENKUPPLUNG				
	d	L	Q1	S1	α ₁
6 1/2	215.9	30.2	200	9	60°
7 1/2	241.3	30.2	222.25	9	45°
8	263.52	62	244.47	11	60°
10	314.32	53.8	295.27	11	45°
11 1/2	352.42	39.6	333.37	11	45°

SAE N.	FLANGIA / FLANGE BRIDE / FLANSCH			
	O	P	Q	α
5	356	314.3	333.4	45°
4	403	362	381	30°
3	451	409.6	428.6	30°
2	490	447.7	466.7	30°

C.G.= GRAVITY CENTER